

# [SCHIENENFÜHRUNGEN]

## Inhalt

NB Bestellbezeichnung.....	3
Laufwagen SGL-F .....	4
Laufwagen SGL-TF .....	5
Laufwagen SGL-HTF.....	6
Laufwagen SGL-HYF.....	7
Laufwagen SGL-E .....	8
Laufwagen SGL-TE .....	9
Laufwagen SGL-HTE.....	10
Laufwagen SGL-HYE.....	11
Laufwagen SGL-HTEX.....	12
Führungsschiene SGL .....	13



## Laufwagen SGL-F

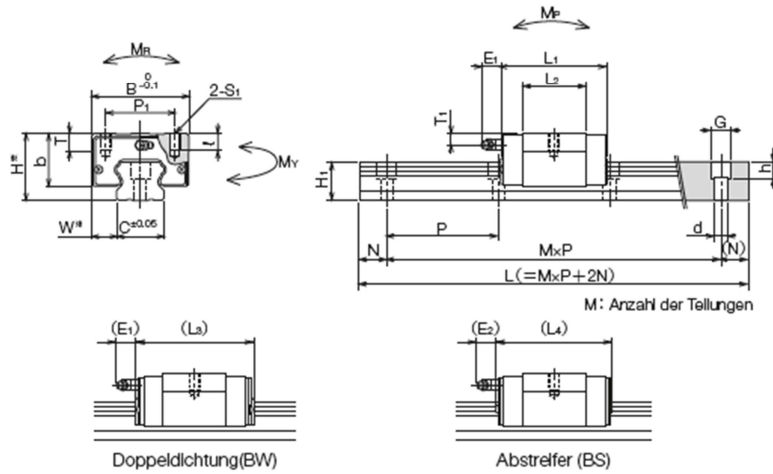

### Laufwagen SGL-F

Teilenummer	Außenabmessungen		Wagenabmessungen												
	H	W	B	L <sub>1</sub>	L <sub>2</sub>	L <sub>3</sub>	L <sub>4</sub>	P <sub>1</sub>	S <sub>1</sub>	ℓ	T	b	E <sub>1</sub>	E <sub>2</sub>	T <sub>1</sub>
	mm	mm	mm	mm	mm	mm	mm	mm	mm	mm	mm	mm	mm	mm	mm
SGL15F SGL15F-D	24	9,5	34	40,7	22,7	46,9	47,3	26	M4	7	6	19,5	6	5,4	5
SGL20F	28	11	42	47,9	29,5	54,1	54,5	32	M5	8	7,5	22	12	11	6
SGL25F	33	12,5	48	58,7	37,7	65,1	65,9	35	M6	9	8	26			6,5
SGL30F	42	16	60	68	40	76,6	75,6	40	M8	12	9	32,5			9
SGL35F	48	18	70	77	46	85,6	84,6	50			13	38			8,5

Wagen Baugröße	Tragzahl		Zulässiges statisches Moment			Masse	
	Dynamisch C kN	Statisch C <sub>0</sub> kN	M <sub>p</sub>	M <sub>v</sub>	M <sub>R</sub>	Wagen kg	Führungs- schiene kg/m
			M <sub>p2</sub> N*m	N*m	N*m		
15	7,29	9,46	37 252	37 252	74	0,1	1,3
20	11,91	14,81	72 447	72 447	159	0,2	2,1
25	17	21,2	123 751	123 751	255	0,3	3
30	23	28,7	195 1263	195 1263	418	0,5	4,6
35	32	37,8	294 1873	294 1873	693	0,8	6,2

## Laufwagen SGL-TF

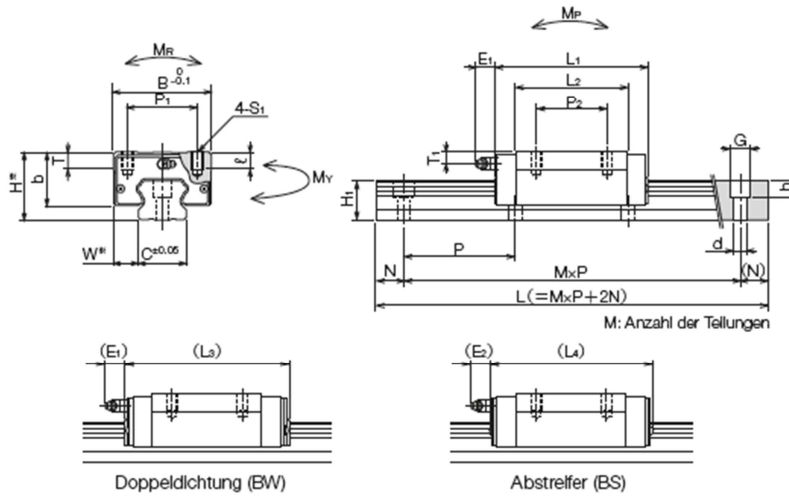

Laufwagen SGL-TF

Teilenummer	Außenabmessungen			Wagenabmessungen												
	H	W	B	L <sub>1</sub>	L <sub>2</sub>	L <sub>3</sub>	L <sub>4</sub>	P <sub>1</sub>	P <sub>2</sub>	S <sub>1</sub>	ℓ	T	b	E <sub>1</sub>	E <sub>2</sub>	T <sub>1</sub>
	mm	mm	mm	mm	mm	mm	mm	mm	mm	mm	mm	mm	mm	mm	mm	mm
SGL15TF SGL15TF-D	24	9,5	34	56,5	38,5	62,7	63,1	26	26	M4	7	6	19,5	6	5,4	5
SGL20TF	28	11	42	65,8	47,4	72	72,4	32	32	M5	8	7,5	22	12	11	6
SGL25TF	33	12,5	48	80	59	86,4	87,2	35	35	M6	9	8	26			6,5
SGL30TF	42	16	60	95,7	67,7	104,3	103,3	40	40	M8	12	9	32,5			9
SGL35TF	48	18	70	109	78	117,6	116,6	50	50			13	38	8,5		

Wagen Baugröße	Tragzahl		Zulässiges statisches Moment			Masse	
	Dynamisch C kN	Statisch C <sub>0</sub> kN	M <sub>P</sub>	M <sub>Y</sub>	M <sub>R</sub>	Wagen kg	Führungs- schiene kg/m
			N*m	N*m	N*m		
15	10,6	162	100	100	127	0,2	1,3
20	16,4	23,3	165	165	250	0,3	2,1
25	24,8	36,3	335	335	437	0,4	3
30	33,6	49,2	529	529	716	0,8	4,6
35	46,7	64,8	796	796	1188	1,3	6,2

Ihr Spezialist für lineare Bewegungssysteme

## Laufwagen SGL-HTF

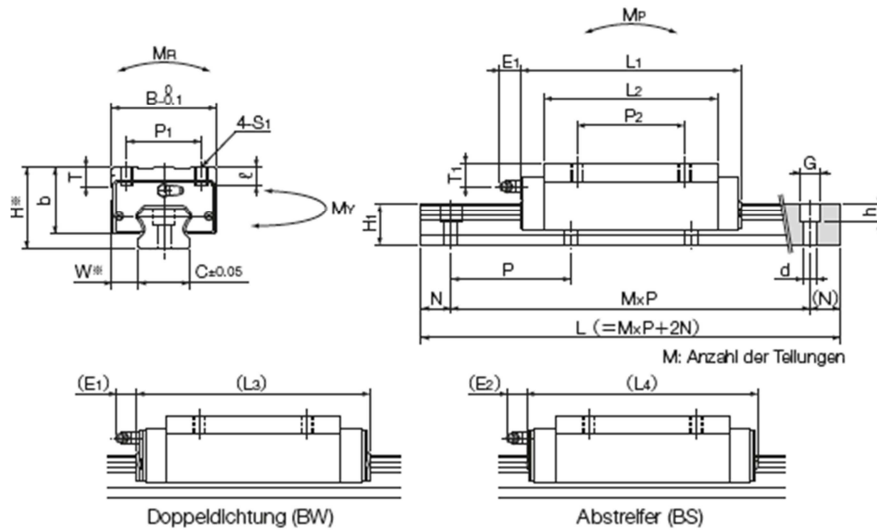

Laufwagen SGL-HTF

Teilenummer	Außenabmessungen			Wagenabmessungen												
	H	W	B	L <sub>1</sub>	L <sub>2</sub>	L <sub>3</sub>	L <sub>4</sub>	P <sub>1</sub>	P <sub>2</sub>	S <sub>1</sub>	ℓ	T	b	E <sub>1</sub>	E <sub>2</sub>	T <sub>1</sub>
	mm	mm	mm	mm	mm	mm	mm	mm	mm	mm	mm	mm	mm	mm	mm	mm
SGL15HTF	28	9,5	34	56,5	38,5	62,7	63,1	26	26	M4	5	6	23,7	6	5,4	9
SGL20HTF	30	12	44	71,6	53,2	77,8	78,2	32	36	M5	6	9,5	24	12	11	8
SGL25HTF	40	12,5	48	80	59	86,4	87,2	35	35	M6	8	9	33			13,5
SGL30HTF	45	16	60	95,7	67,7	104,3	103,3	40	40	M8	10	35,5	12			
SGL35HTF	55	18	70	109	78	117,6	116,6	50	50		12	13	45			15,5
SGL45HTF	70	20,5	86	139	102	147,5	148	60	60	M10	17	15	60	15	15	20

Wagen Baugröße	Tragzahl		Zulässiges statisches Moment			Masse	
	Dynamisch C kN	Statisch C <sub>0</sub> kN	M <sub>p</sub>	M <sub>v</sub>	M <sub>R</sub>	Wagen kg	Führungs- schiene kg/m
			N*m	N*m	N*m		
15	10,60	16,20	100,00	100,00	127,00	0,20	1,30
20	18,40	27,50	227,00	227,00	296,00	0,40	2,10
25	24,80	36,30	335,00	335,00	437,00	0,60	3,00
30	33,60	49,20	529,00	529,00	716,00	0,90	4,60
35	46,70	64,80	796,00	796,00	1.188,00	1,50	6,20
45	74,80	101,20	1.553,00	1.553,00	2.312,00	3,10	10,50

## Laufwagen SGL-HYF

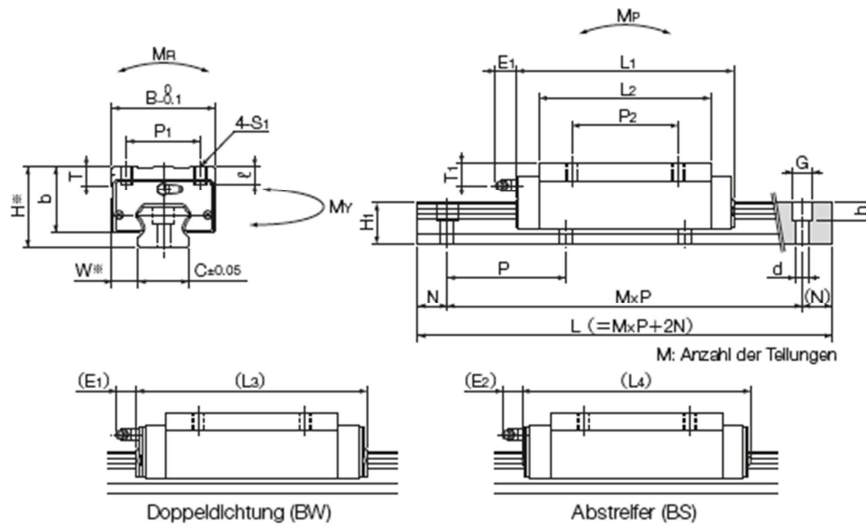

Laufwagen SGL-HYF

Teilenummer	Außenabmessungen			Wagenabmessungen												
	H	W	B	L <sub>1</sub>	L <sub>2</sub>	L <sub>3</sub>	L <sub>4</sub>	P <sub>1</sub>	P <sub>2</sub>	S <sub>1</sub>	ℓ	T	b	E <sub>1</sub>	E <sub>2</sub>	T <sub>1</sub>
	mm	mm	mm	mm	mm	mm	mm	mm	mm	mm	mm	mm	mm	mm	mm	mm
SGL15HYF	28	9,5	34	79	61	82,5	85,5	26	26	M4	5	6	23,7	6	5,4	9
SGL20HYF	30	12	44	96	77,6	102,2	102,6	32	50	M5	6	9,5	24	12	11	8
SGL25HYF	40	12,5	48	109	88	115,4	116,2	35	50	M6	8	9	33			13,5
SGL30HYF	45	16	60	129	101	137,6	136,6	40	60	M8	10	35,5	12			
SGL35HYF	55	18	70	147	116	155,6	154,6	50	72		12	13	45			15,5
SGL45HYF	70	20,5	86	171	134	179	180	60	80	M10	17	15	60	15	15	20

Wagen Baugröße	Tragzahl		Zulässiges statisches Moment			Masse	
	Dynamisch C kN	Statisch C <sub>0</sub> kN	M <sub>P</sub>	M <sub>V</sub>	M <sub>R</sub>	Wagen kg	Führungs- schiene kg/m
			N*m	N*m	N*m		
15	14,60	25,60	238,00	238,00	200,00	0,30	1,30
20	23,90	40,20	467,00	467,00	432,00	0,50	2,10
25	32,80	54,50	723,00	723,00	655,00	0,90	3,00
30	44,60	73,80	1.144,00	1.144,00	1.074,00	1,30	4,60
35	61,90	97,20	1.722,00	1.722,00	1.782,00	2,20	6,20
45	91,40	134,90	2.681,00	2.681,00	3.082,00	4,00	10,50

## Laufwagen SGL-E

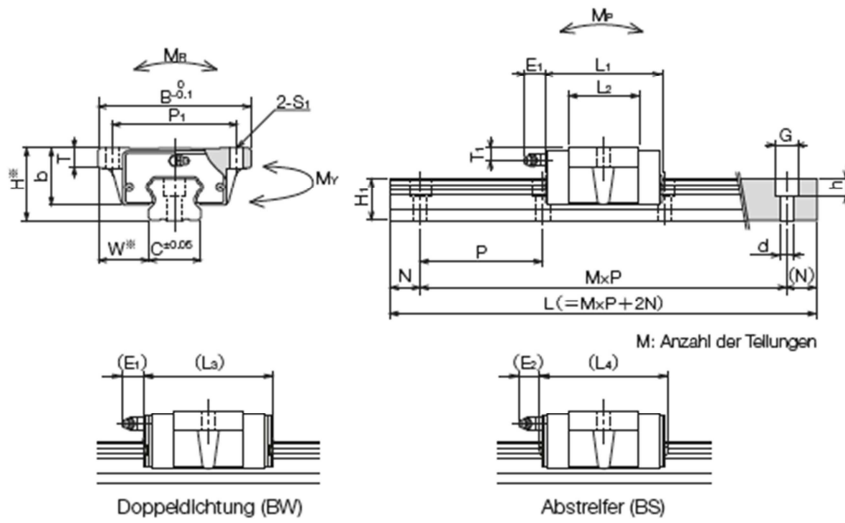

Laufwagen SGL-E

Teilenummer	Außenabmessungen		Wagenabmessungen											
	H	W	B	L <sub>1</sub>	L <sub>2</sub>	L <sub>3</sub>	L <sub>4</sub>	P <sub>1</sub>	S <sub>1</sub>	T	b	E <sub>1</sub>	E <sub>2</sub>	T <sub>1</sub>
	mm	mm	mm	mm	mm	mm	mm	mm	mm	mm	mm	mm	mm	mm
SGL15E SGL15E-D	24	18,5	52	40,7	22,7	46,9	47,3	41	4,5	7	19,5	6	5,4	5
SGL20E	28	19,5	59	47,9	29,5	54,1	54,5	49	5,5	9	22	12	11	6
SGL25E	33	25	73	58,7	37,7	65,1	65,9	60	7	10	26			6,5
SGL30E	42	31	90	68	40	76,6	75,6	72	9		32,5			9
SGL35E	48	33	0	77	64	85,6	84,6	82		13	38			8,5

Wagen Baugröße	Tragzahl		Zulässiges statisches Moment			Masse	
	Dynamisch C kN	Statisch C <sub>0</sub> kN	M <sub>p</sub> M <sub>p2</sub> N*m	M <sub>y</sub> M <sub>y2</sub> N*m	M <sub>r</sub> N*m	Wagen kg	Führungs- schiene kg/m
15	7,29	9,46	37 252	37 252	74,00	0,10	1,30
20	11,91	14,81	72 447	72 447	159,00	0,20	2,10
25	17,00	21,20	123 751	123 751	255,00	0,40	3,00
30	23,00	28,70	195 1263	195 1263	418,00	0,60	4,60
35	32,00	37,80	294 1873	294 1873	693,00	0,90	6,20

## Laufwagen SGL-TE

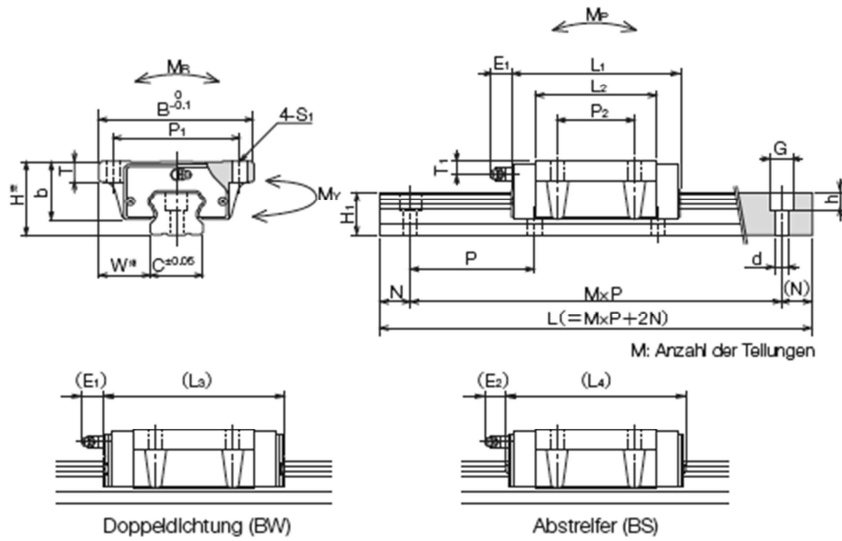

## Laufwagen QEW-SC / QEW-CC

Teilenummer	Außenabmessungen		Wagenabmessungen												
	H	W	B	L <sub>1</sub>	L <sub>2</sub>	L <sub>3</sub>	L <sub>4</sub>	P <sub>1</sub>	P <sub>2</sub>	S <sub>1</sub>	T	b	E <sub>1</sub>	E <sub>2</sub>	T <sub>1</sub>
	mm	mm	mm	mm	mm	mm	mm	mm	mm	mm	mm	mm	mm	mm	mm
SGL15TE SGL15E-D	24	18,5	52	56,5	38,5	62,7	63,1	41	26	4,5	7	19,5	6	5,4	5
SGL20TE	28	19,5	59	65,8	47,4	72	72,4	49	32	5,5	9	22	12	11	6
SGL25TE	33	25	73	80	59	86,4	87,2	60	35	7	10	26			6,5
SGL30TE	42	31	90	95,7	67,7	104,3	103,3	72	40	9		32,5			9
SGL35TE	48	33	100	109	78	117,6	116,6	82	50		13	38			8,5

Wagen Baugröße	Tragzahl		Zulässiges statisches Moment			Masse	
	Dynamisch C kN	Statisch C <sub>0</sub> kN	M <sub>p</sub> M <sub>p2</sub> N*m	M <sub>y</sub> M <sub>y2</sub> N*m	M <sub>R</sub> N*m	Wagen kg	Führungs- schiene kg/m
15	10,60	16,20	100,00	100,00	127,00	0,20	1,30
20	16,40	23,30	165,00	165,00	250,00	0,30	2,10
25	24,80	36,30	335,00	335,00	437,00	0,60	3,00
30	33,60	49,20	529,00	529,00	716,00	1,00	4,60
35	46,70	64,80	796,00	796,00	1.188,00	1,50	6,20

## Laufwagen SGL-HTE

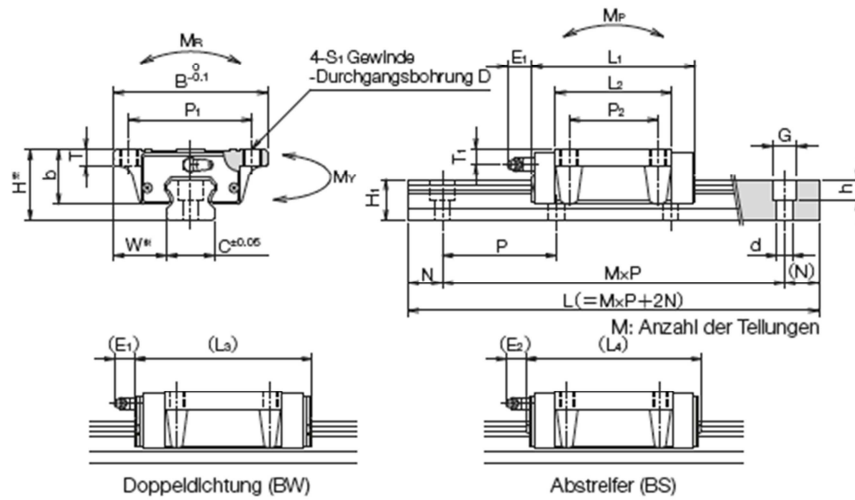

Laufwagen SGL-HTE

Teilenummer	Außenabmessungen			Wagenabmessungen												
	H	W	B	L <sub>1</sub>	L <sub>2</sub>	L <sub>3</sub>	L <sub>4</sub>	P <sub>1</sub>	P <sub>2</sub>	S <sub>1</sub>	D	T	b	E <sub>1</sub>	E <sub>2</sub>	T <sub>1</sub>
	mm	mm	mm	mm	mm	mm	mm	mm	mm	mm	mm	mm	mm	mm	mm	mm
SGL15HTE	24	16	47	56,5	38,5	62,7	63,1	38	30	M5	4,4	7,5	19,7	6	5,4	5
SGL20HTE	30	21,5	63	71,6	53,2	77,8	78,2	53	40	M6	5,4	10,5	24	12	11	8
SGL25HTE	36	23,5	70	80	59	86,4	87,2	57	45	M8	6,8	12,5	29			9,5
SGL30HTE	42	31	90	95,7	67,7	104,3	103,3	72	52	M10	8,5	10	32,5			9
SGL35HTE	48	33	100	109	78	117,6	116,6	82	62			13	38			8,5
SGL45HTE	60	37,5	120	139	102	147,5	148	100	80	M12	10,5	15	50	15	15	10

Wagen Baugröße	Tragzahl		Zulässiges statisches Moment			Masse	
	Dynamisch C kN	Statisch C <sub>0</sub> kN	M <sub>P</sub> M <sub>P2</sub> N*m	M <sub>Y</sub> M <sub>Y2</sub> N*m	M <sub>R</sub> N*m	Wagen kg	Führungs- schiene kg/m
15	10,60	16,20	100,00	100,00	127,00	0,20	1,30
20	18,40	27,50	227,00	227,00	296,00	0,40	2,10
25	24,80	36,30	335,00	335,00	437,00	0,60	3,00
30	33,60	49,20	529,00	529,00	716,00	1,00	4,60
35	46,70	64,80	796,00	796,00	1.188,00	1,50	6,20
45	74,80	101,20	1.553,00	1.553,00	2.312,00	3,10	10,50

## Laufwagen SGL-HYE

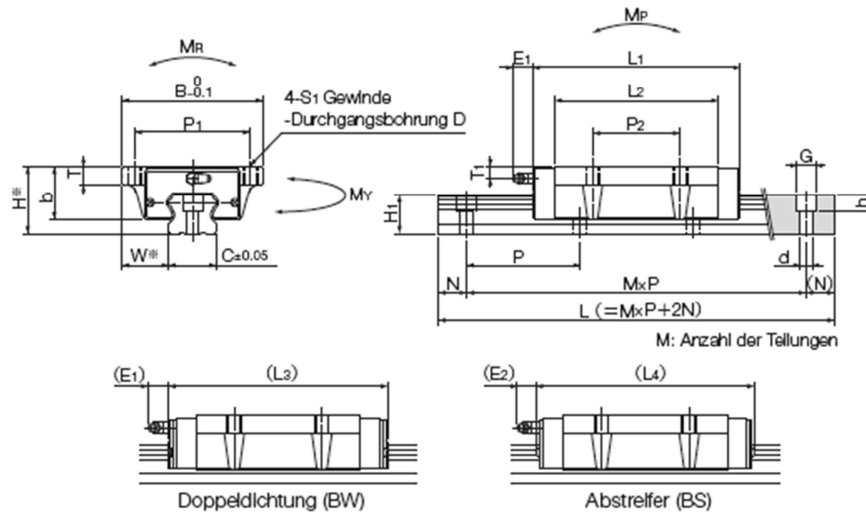

Laufwagen SGL-HYE

Teilenummer	Außenabmessungen		Wagenabmessungen													T <sub>1</sub>
	H	W	B	L <sub>1</sub>	L <sub>2</sub>	L <sub>3</sub>	L <sub>4</sub>	P <sub>1</sub>	P <sub>2</sub>	S <sub>1</sub>	D	T	b	E <sub>1</sub>	E <sub>2</sub>	
	mm	mm	mm	mm	mm	mm	mm	mm	mm	mm	mm	mm	mm	mm	mm	
SGL15HYE	24	16	47	79	61	85,2	85,6	38	30	M5	4,4	7,5	19,7	6	5,4	5
SGL20HYE	30	21,5	63	96	77,6	102,2	102,6	53	40	M6	5,4	10,5	24	12	11	8
SGL25HYE	36	23,5	70	109	88	115,4	116,2	57	45	M8	6,8	12,5	29			9,5
SGL30HYE	42	31	90	129	101	137,6	136,6	72	52	M10	8,5	10	32,5			9
SGL35HYE	48	33	100	147	116	155,6	154,6	82	62			13	38			8,5
SGL45HYE	60	37,5	120	171	134	179,5	180	100	80	M12	10,5	15	50	15	15	10

Wagen Baugröße	Tragzahl		Zulässiges statisches Moment			Masse	
	Dynamisch C kN	Statisch C <sub>0</sub> kN	M <sub>p</sub> M <sub>p2</sub> N*m	M <sub>y</sub> M <sub>y2</sub> N*m	M <sub>r</sub> N*m	Wagen kg	Führungs- schiene kg/m
15	14,60	25,60	238,00	238,00	200,00	0,30	1,30
20	23,90	40,20	467,00	467,00	432,00	0,70	2,10
25	32,80	54,50	723,00	723,00	655,00	1,00	3,00
30	44,60	73,80	1.144,00	1.144,00	1.074,00	1,50	4,60
35	61,90	97,20	1.722,00	1.722,00	1.782,00	2,20	6,20
45	91,40	134,90	2.681,00	2.681,00	3.082,00	4,00	10,50

## Laufwagen SGL-HTEX

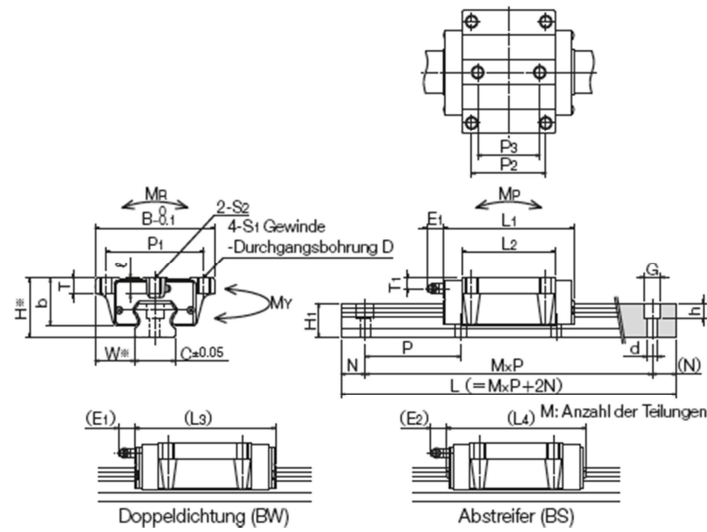

Laufwagen SGL-HTEX

Teilenummer	ußenabmessungen			Wagenabmessungen																
	H	W	B	L <sub>1</sub>	L <sub>2</sub>	L <sub>3</sub>	L <sub>4</sub>	P <sub>1</sub>	P <sub>2</sub>	S <sub>1</sub>	D	T	P <sub>3</sub>	S <sub>2</sub>	ℓ	b	E <sub>1</sub>	E <sub>2</sub>	T <sub>1</sub>	
	mm	mm	mm	mm	mm	mm	mm	mm	mm		mm	mm	mm		mm	mm	mm	mm	mm	
SGL15HTEX	24	16	47	56,5	38,5	62,7	63,1	38	30	M5	4,4	7,5	26	M5	6	19,7	6	5,4	5	
SGL20HTEX	30	21,5	63	71,6	53,2	77,8	78,2	53	40	M6	5,4	10,5	35	M6	8	24	12	11	8	
SGL25HTEX	36	23,5	70	80	59	86,4	87,2	57	45	M8	6,8	12,5	40	M8	10	29			9,5	
SGL30HTEX	42	31	90	95,7	67,7	104,3	103,3	72	52	M10	8,5	10	44	M10	10	32,5			9	
SGL35HTEX	48	33	100	109	78	117,6	116,6	82	62			13	52		13	38			8,5	
SGL45HTEX	60	37,5	120	139	102	147,5	148	100	80	M12	10,5	15	60	M12	14	50	15	15	10	

Wagen Baugröße	Tragzahl		Zulässiges statisches Moment			Masse	
	Dynamisch C kN	Statisch C <sub>0</sub> kN	M <sub>p</sub> M <sub>p2</sub> N*m	M <sub>y</sub> M <sub>y2</sub> N*m	M <sub>r</sub> N*m	Wagen kg	Führungs- schien
15	10,60	16,20	100,00	100,00	127,00	0,20	1,30
20	18,40	27,50	227,00	227,00	296,00	0,40	2,10
25	24,80	36,30	335,00	335,00	437,00	0,60	3,00
30	33,60	49,20	529,00	529,00	716,00	1,00	4,60
35	46,70	64,80	796,00	796,00	1.188,00	1,50	6,20
45	74,80	101,20	1.553,00	1.553,00	2.312,00	3,10	10,50

## Führungsschiene SGL

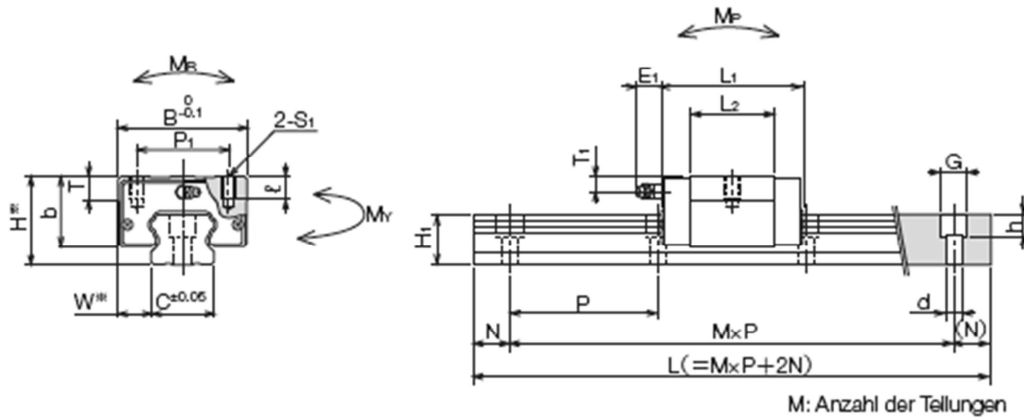

Laufwagen MGN-C / MGN-H

Teile- nummer	Abmessungen der Führungsschienen				
	$H_1$	C	dxGxh	N	P
SGL15	13,5	15	3,5x6x4,5	20	60
SGL20	16	20	4,5x7,5x5,3		
SGL25	20	23	6,9x9,5x8,5		
SGL30	24	28	7x11x9		80
SGL35	27,5	34	9x14x12		