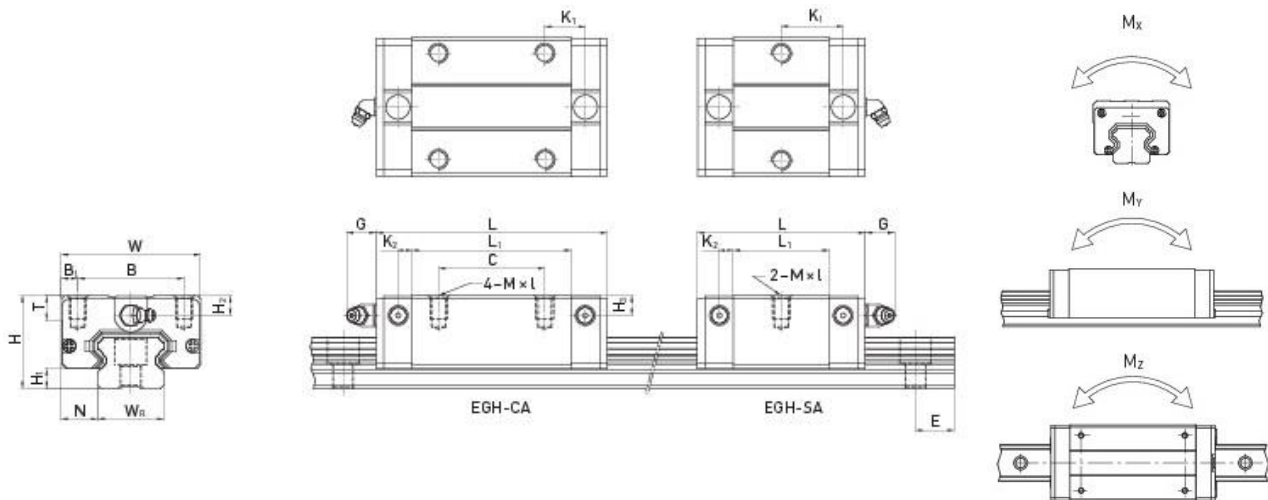

Ihr Spezialist für lineare Bewegungssysteme

**Laufwagen HGH-CC / HGH-HA**

**Laufwagen HGH-CC / HGH-HA**

Baureihe	Montagemaße [mm]			Abmessung des Laufwagens [mm]														Gewicht [kg]
	H	H <sub>1</sub>	N	W	B	B <sub>1</sub>	C	L <sub>1</sub>	L	K <sub>1</sub>	K <sub>2</sub>	G	M x l	T	H <sub>2</sub>	H <sub>3</sub>		
HGH15CA	28	4,3	9,5	34	26	4	26	39,4	61,4	10	4,85	5,3	M4 x 5	6	7,95	7,7	0,18	
HGH20CA	30	4,6	12	44	32	6	36	50,5	77,5	12,25	6	12	M5 x 6	8	6	6	0,3	
HGH20HA	30	4,6	12	44	32	6	50	65,2	92,2	12,6	6	12	M5 x 6	8	6	6	0,39	
HGH25CA	40	5,5	12,5	48	35	6,5	35	58	84	16,8	6	12	M6 x 8	8	10	9	0,51	
HGH25HA	40	5,5	12,5	48	35	6,5	50	78,6	104,6	19,6	6	12	M6 x 8	8	10	9	0,69	
HGH30CA	45	6	16	60	40	10	40	70	97,4	20,25	6	12	M8 x 10	8,5	9,5	13,8	0,88	
HGH30HA	45	6	16	60	40	10	60	93	120,4	21,75	6	12	M8 x 10	8,5	9,5	13,8	1,16	
HGH35CA	55	7,5	18	70	50	10	50	80	112,4	20,6	7	12	M8 x 12	10,2	16	19,6	1,45	
HGH35HA	55	7,5	18	70	50	10	72	105,8	138,2	22,5	7	12	M8 x 12	10,2	16	19,6	1,92	
HGH45CA	70	9,5	20,5	86	60	13	60	97	139,4	23	10	12,9	M10 x 17	16	18,5	30,5	2,73	
HGH45HA	70	9,5	20,5	86	60	13	80	128,8	171,2	28,9	10	12,9	M10 x 17	16	18,5	30,5	3,61	
HGH55CA	80	13	23,5	100	75	12,5	75	117,7	166,7	27,35	11	12,9	M12 x 18	17,5	22	29	4,17	
HGH55HA	80	13	23,5	100	75	12,5	95	155,8	204,8	36,4	11	12,9	M12 x 18	17,5	22	29	5,49	
HGH65CA	90	15	31,5	126	76	25	70	144,2	200,2	43,1	14	12,9	M16 x 20	25	15	15	7	
HGH65HA	90	15	31,5	126	76	25	120	203,6	259,6	47,8	14	12,9	M16 x 20	25	15	15	9,82	

Baureihe	Dynamische Tragzahl C [N]*	Statische Tragzahl C <sub>0</sub> [N]	Dynamisches Moment [Nm]			Statisches Moment [Nm]		
			M <sub>x</sub>	M <sub>y</sub>	M <sub>z</sub>	M <sub>0x</sub>	M <sub>0y</sub>	M <sub>0z</sub>
HG_15C	11380	25310	76	67	67	170	150	150
HG_20C	17750	37840	178	126	126	380	270	270
HG_20H	21180	48840	208	203	203	480	470	470
HG_25C	26480	56190	301	240	240	640	510	510
HG_25H	32750	76000	374	379	379	870	880	880
HG_30C	38740	83060	494	396	396	1060	850	850
HG_30H	47270	110130	600	630	630	1400	1470	1470
HG_35C	49520	102870	832	577	577	1730	1200	1200
HG_35H	60210	136310	1011	918	918	2290	2080	2080
HG_45C	77570	155930	1497	1169	1169	3010	2350	2350
HG_45H	94540	207120	1825	1857	1857	4000	4070	4070
HG_55C	114440	227810	2843	2039	2039	5660	4060	4060
HG_55H	139350	301260	3464	3242	3242	7490	7010	7010
HG_65C	163630	324710	5049	3245	3245	10020	6440	6440
HG_65H	208360	457150	6449	5068	5068	14150	11120	11120

## Bestellbezeichnung

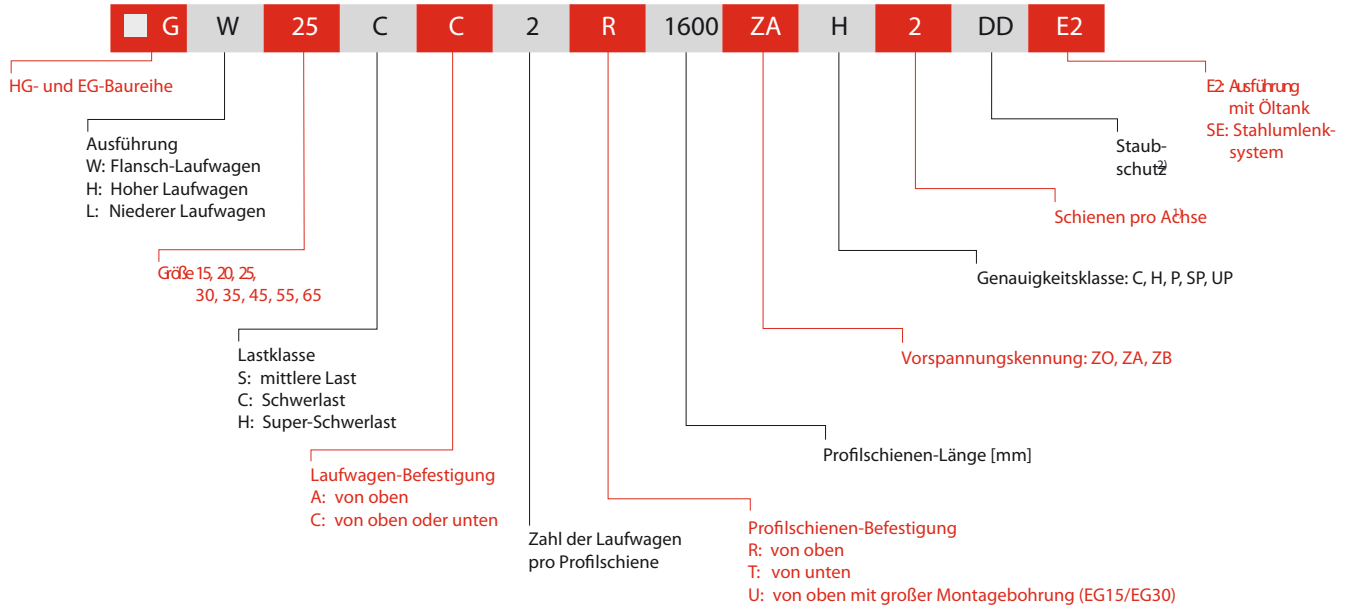
### I. Nicht austauschbare Modelle (kundenspezifisch konfektioniert)



### II. Austauschbare Modelle

#### ○ Artikelnummer des HG/EG-Laufwagens

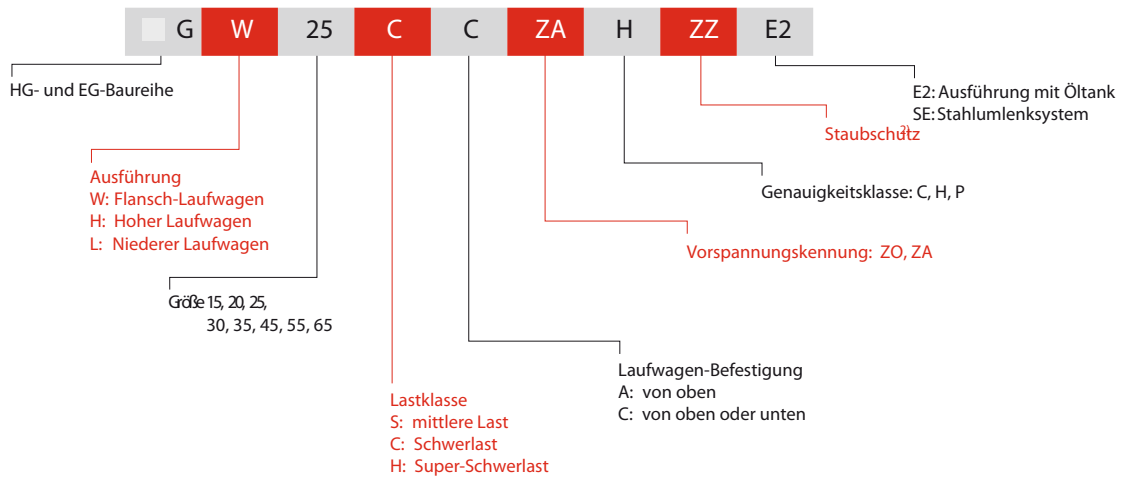

#### ○ Artikelnummer der HG/EG-Profilschiene

